

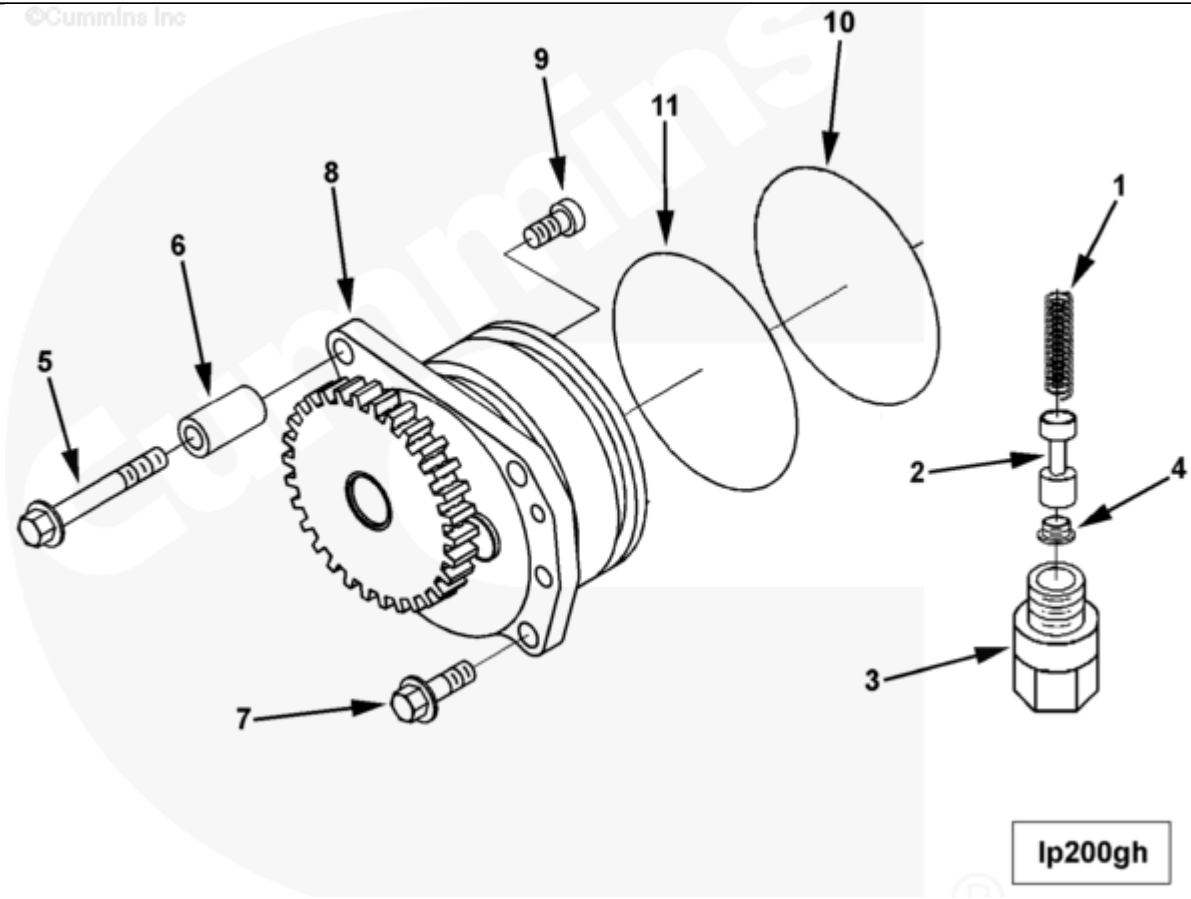

Parts Catalog - Option Detail

Electronic Parts Catalog - Option Detail				
Option	Group	Graphic	Film Card	Date
LP2709-03	07.06	lp200gh	II	19-DEC-03
Engines	ISM CM570, ISM CM570/870, ISM CM875, ISM CM876, ISM CM876 E, ISM11 CM876 M103, ISM11 CM876 SN, M11 CELECT, M11 CELECT PLUS, M11 MECHANICAL, QSM11 CM570, QSM11 CM876			



[SMALL](#) | [MEDIUM](#) | [LARGE](#)

Cart	Ref No	Part Number	Part Description	Required	Remarks
View My Cart					
		LP2709-03	Lubricating Oil Pump		
					Lube Oil Pump
					Capacity: 48 GPM Max
					Contains Retainer Plug
					Lube Oil Suction Tube

					Arrangement: Block Mounted
					Oil Pan Sump Location: Front
					Unique Characteristics:
					Maximum Engine Family Line
					Haul Rating 400 HP or Less
<input type="checkbox"/>	1	3010146	Compression Spring	1	
<input type="checkbox"/>	2	3068979	Pressure Regulator Plunger	1	
<input type="checkbox"/>	3	3069728	Viscosity Sensor	1	Oil.
<input type="checkbox"/>	4	3895718	Retainer Plug	1	
<input type="checkbox"/>	5	3895438	Hexagon Flange Head Cap Screw	2	M8 x 1.25 x 60
<input type="checkbox"/>	6	3895439	Mounting Spacer	2	
<input type="checkbox"/>	7	3895440	Hexagon Flange Head Cap Screw	1	M8 x 1.25 x 25
<input type="checkbox"/>	8	4003950	Lubricating Oil Pump	1	
<input type="checkbox"/>	9	3023525	Socket Head Cap Screw	4	M8 x 1.25 x 20
<input type="checkbox"/>	10	3033247	O-Ring Seal	1	
<input type="checkbox"/>	11	3033248	O-Ring Seal	1	